

??号

CAD

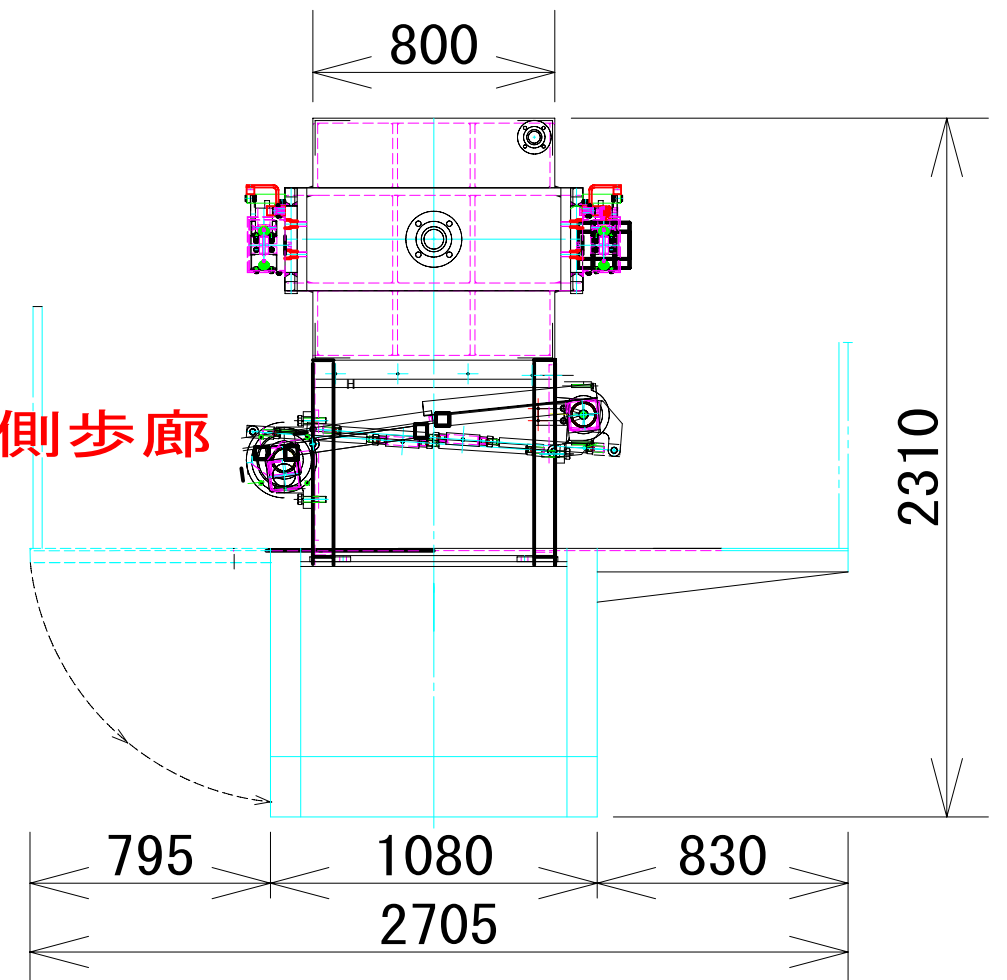
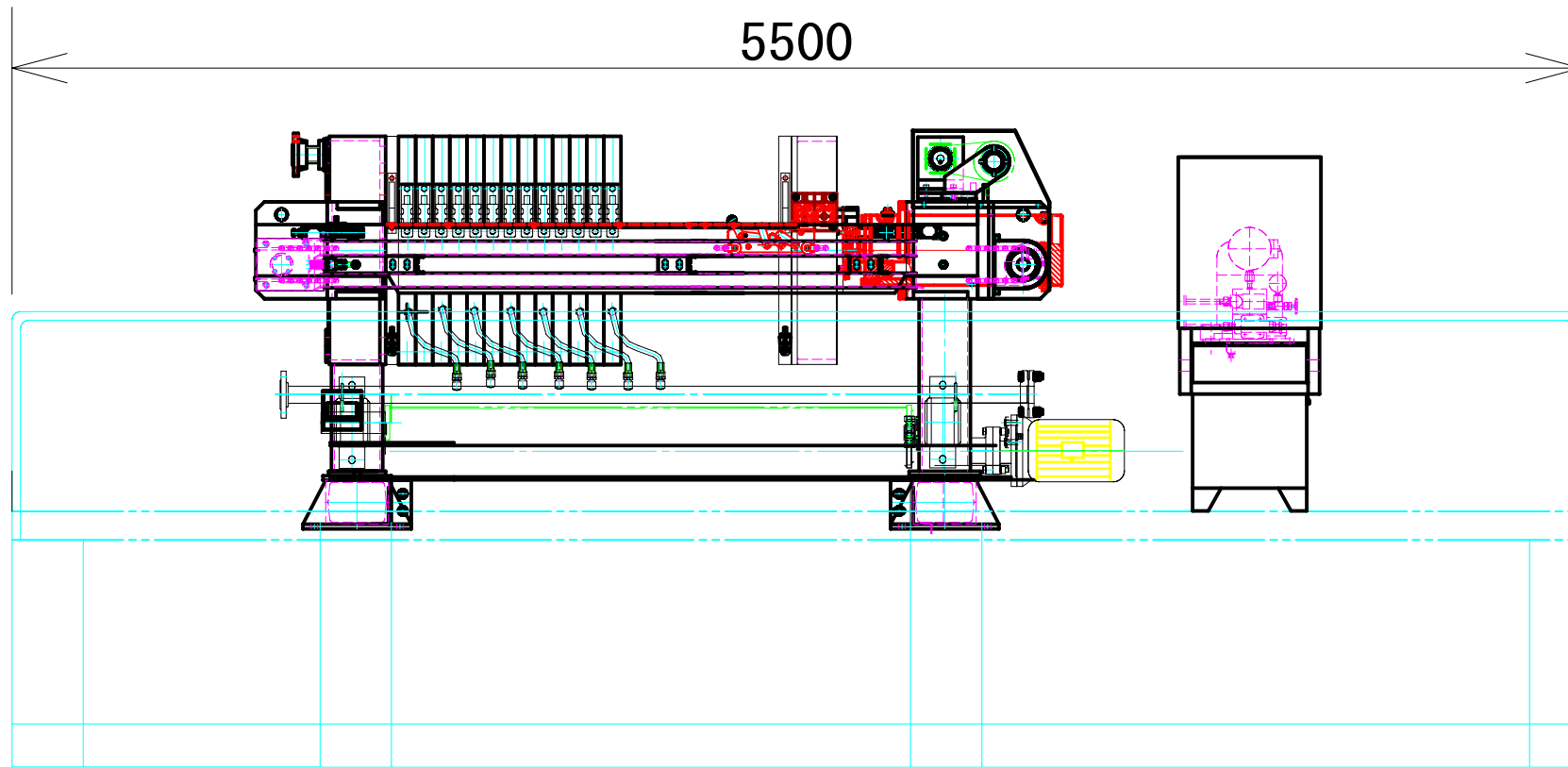

会?

可動側步廊

Name	spec.	Name	Spec.
Filtering area ² (m)	15	chamber volume (m ³)	0.236
Max Temp (°C)	60	Max filtering pressure (Mpa)	1.0
Max hydraulic protect pressure, Mpa	29	cylinder stroke, mm	450
Max hydraulic close pressure, Mpa	25	cylinder diameter, mm	200
Plate Qty., pcs	7+6+1+1	Oil pump motor 4KW: 220V 60HZ	
Plate thickness (mm)	58/65		
Cake thickness (mm)	30		
Max squeezing Mpa	1.0	Total weight, kgs	2850

描 ?

描 校

旧底?登?号

底?登?号

				800 membrane filter press GA		D NO. : 2019081602	
?? ?数	更改文件号?	字	日期	?? ?? ?	重量	比例	
?	?	工	?	S			1:35
?	?	准化	?	共	?	第	?
?	校	批	准	GA			
日期				HANGZHOU LEO FILTER PRESS CO., LTD			